

- (b) Consider a linear discrete data control system whose input-output relation is described by the following difference equation:

$$c(k+2) + 2c(k+1) + c(k) = u(k)$$

- (i) Determine the system controllability and observability.
 (ii) Show that the observability of the system can be changed through state feedback (show that choosing the system output will affect your solution)

- (3) (a) For the system shown in the Fig. 2:

(28 Marks)

$$m(k) = 5m(k-1) + 0.3e(k)$$

The sampling rate is 1 Hz

- (i) Find the system type.
 (ii) Find the system transfer function $C(z)/R(z)$.
 (iii) Find $c(kT)$ for unit step input.
 (iv) Find the steady state value for unit step response you got in (iii).
 (v) Find the steady state error.

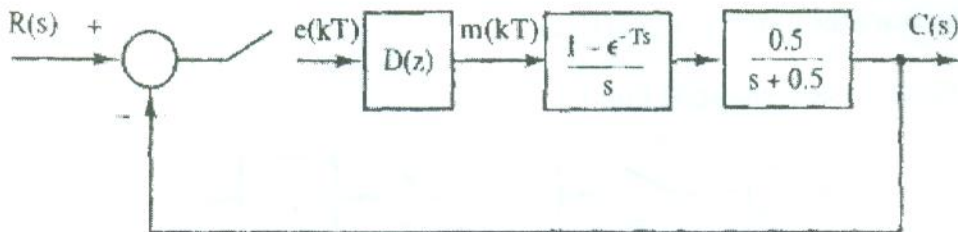

Fig. 2

- (b) For the system shown in Fig. 3:

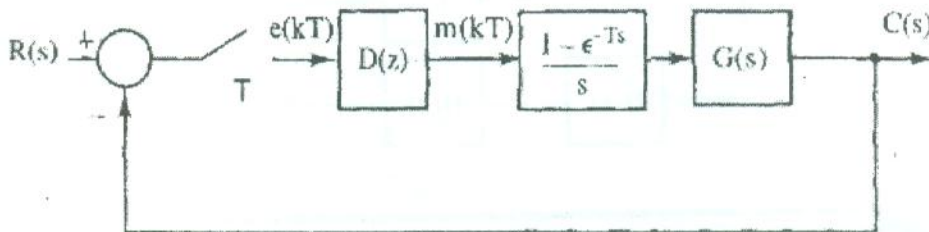

Fig. 3

- (i) Find the range of K for the system to be stable using Routh Hurwitz Criterion when $D(z) = 1$, $G(s) = \frac{K}{s(s+1)}$, and $T=1$ sec.
 (ii) If $D(z) = \frac{10z}{z-1} + K_p$, $G(s) = \frac{1}{(s+1)}$ and $T=0.1$ sec, find the range of K_p for the system to be stable using Jury's test.

- (4) (a) explain what is meant by state observer. Show by block diagram how it works? (17 Marks)

- (b) Consider the state space model of a servo motor with a sampling period $T=0.1$ sec

$$x(k+1) = \begin{bmatrix} 1.35 & 0.55 \\ -0.45 & 0.35 \end{bmatrix} x(k) + \begin{bmatrix} 0.5 \\ 0.5 \end{bmatrix} u(k)$$

$$y(k) = [1 \ 0]x(k)$$

- (i) Determine the gain matrix K such that the desired closed loop poles are located at $Z_{1,2} = 0.888 \pm j 0.173$.
- (ii) Design a full state observer such that the time constant of the observer poles is one half the time constant of the desired closed loop poles in part b. Choose the observer poles to be real and equal (hint: time constant = $\frac{-T}{\ln r}$, where r is the real part of the closed loop poles).

Good Luck

Dr. Ahmed Elmogy

Time function	Laplace transform	Z-Transform
$\delta(t)$	1	1
$\delta(t - kT)$	e^{-kTs}	z^{-k}
$u(t)$	$\frac{1}{s}$	$\frac{z}{z-1}$
e^{-at}	$\frac{1}{s+a}$	$\frac{z}{z - e^{-aT}}$
T	$\frac{1}{s^2}$	$\frac{Tz}{(z-1)^2}$
t^2	$\frac{2}{s^3}$	$\frac{T^2 z(z+1)}{(z-1)^3}$



Answer the following questions:

(1) (a) The system described by the equations:

(19 Marks)

$$x(k+1) = \begin{bmatrix} 1 & 0 \\ 0 & 0.5 \end{bmatrix} x(k) + \begin{bmatrix} 2 \\ 1 \end{bmatrix} u(k)$$

$$y(k) = [1 \quad 2]x(k)$$

Is excited by the initial conditions $x(0) = [1 \quad 2]^T$ with $u(k) = 1$ for all k

- (i) Solve for $x(k), 0 \leq k \leq 2$.
- (ii) Find the output $y(k)$.
- (iii) Find the transfer function $Y(Z)/U(z)$.

(b) Find $C(z)$ for the system shown in Fig. 1

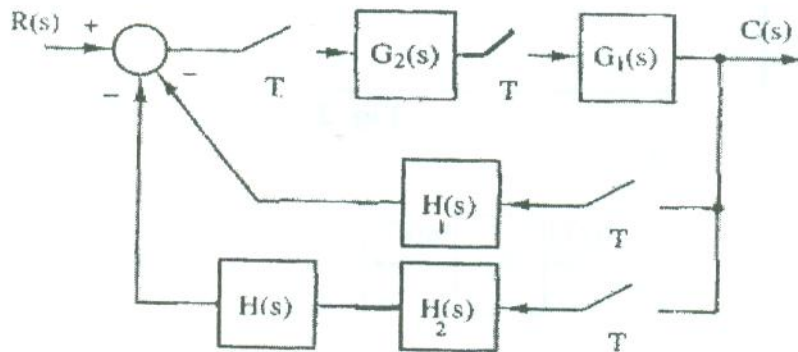

Fig.1

(2) (a) For the system described by the following difference equation:

(26 Marks)

$$y(k+2) + 3y(k+1) + 5y(k) = 3u(k+1) + 2u(k)$$

Assuming zero conditions, find:

- (i) Find the state space model for the given system.
- (ii) Find unit step response.
- (iii) Find the final value of the step response using two methods (comment in your answer).
- (iv) Check the system stability.

Question 3 (30 points)

- a) In the search graph shown in Figure 1, let A be the initial node and G be the goal node. The numbers on the edges are the edge costs. Assume the successor function generates nodes in increasing order of edge cost.
- What will be the order of node expansions using each of the following search algorithms:
 - depth-first search.
 - iterative-deepening search.
 - A* search using the heuristic function that gives the minimum number of edges to be traversed to reach a goal (costs not considered). The function g_e is the depth of the node.
 - Is the heuristic used with A* admissible? Briefly justify.
- b) The goal of the 4-queen problem is to place 4 queens on a chessboard such that no queen attacks any others (A queen attacks any piece in the same row, column, or diagonal)
- Formulate the given problem using CSP.
 - Show how the forward checking algorithm can be used to solve the problem. (A possible solution is given in Figure 2).

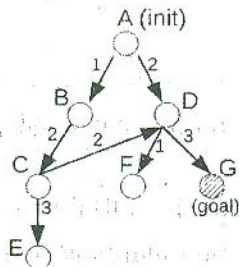

Figure 1: Search graph



Figure 2: A possible solution.

Question 4 (30 points)

- a. Translate the following sentences into First-order logic:
- There exist computers that are Apples.
 - All laptops are computers.
 - All computers run Unix.
 - Apples don't run Windows.
- b. Given the following KB, prove R using the resolution algorithm.
- S1: $P \vee Q$
 - S2: $P \rightarrow R$
 - S3: $Q \rightarrow R$
- c. The law says that it is a crime for an Egyptian to receive money from hostile nations. The country SOSO, an enemy of Egypt has given money to some Egyptian organizations. Mr. Mubarak, who is Egyptian, was the president of these organizations.
- Using FOL to represent this KB.
 - Using the forward chaining algorithm to prove that Mr. Mubarak is a criminal.

With my best wishes,
Dr. Ing. Alsayed Algergawy

Answer the following questions. Your answers should be precise and brief.

Question 1 (15 points)

Tell whether each of the following statements is true or false, and then correct the false ones:

1. A sentence is satisfiable if it is true in all models.
2. Nodes in constraint graph represent variables' values.
3. In the greedy best-first search strategy, we should keep all nodes in memory.
4. A knowledge base is a set of sentences in an informal language.
5. In a search tree, a node is equivalent to a state.
6. Breadth-first search is an optimal and complete search strategy.
7. A complete search strategy will always find an optimal solution.
8. $C \wedge D \implies B$ is an example of Horn clause.
9. The full power of the resolution algorithm is needed in many real-world cases.
10. A simple reflex agent selects actions based on both the current percept and the percept history.
11. An optimal solution to a problem is a path from the initial state to a goal state.
12. The agent program implements the agent function mapping percepts to actions.
13. In a search tree, two different nodes can contain the same world state.
14. A heuristic that is good for a given problem is also good for any other problem.
15. The MRV helps at all in choosing the first variable to start.

Question 2 (15 points)

Complete the following sentences:

1. A knowledge-based agent consists of two main components: and
2. The simple reflex agent is implemented using rules.
3. Both the initial state and successor function form the of the problem.
4. A problem can be defined formally by four components:,, and
5. In search tree, methods used to implement fringe are, and
6. $\alpha \implies \beta$ is equivalent to
7. Iterative deepening search is optimal if
8. Propositional logic assumes the world contains, while First-order logic (FOL) assumes the world contains, and
9. Space complexity of uniform-cost search is
10. is the FOL representation of the sentence "Someone at ENG is smart".

bounced check letter to the customer requesting are placement check plus a \$15.00 penalty (this is now included as part of the outstanding balance). Bounced checks are never re-deposited.

Question three

- 1) Define each of the following terms: Transitive dependences, Normalization and Functional dependency.
- 2) Differentiate between the operational Database and Data Warehouse
- 3) The following table contains sample data for parts and for vendors who supply those parts. Perform the following activities at the table:
 - a- Convert the relations in this table into the first normal form.
 - b- Perform the second normal form to the previous resulted relations.
 - c- Develop a set of third normal form at the resulted relations.

Part Number	Description	Vendor Name	Address	Unit Cost
1234	Logic chip	Fast Chips	Intel	10.00
		Smart Chips	IBM	8.00
5678	Memory chip	Fast Chips	Intel	3.00
		Quality Chips	Phoenix	2.00
		Smart Chips	IBM	5.00

Question Four

- 1- A data warehouse is a subject-oriented, integrated, time-variant, and nonvolatile. Explain each underline term according the definition of data warehouse.
- 2-Pick and Shovel Construction Company is a multi-state building contractor specializing in medium-priced town homes. Assume that Pick and Shovel’s main entities are its customers, employees, projects and equipment. A customer can hire the company for more than one project, and employees sometimes work on more than one project at a time. Equipment, however, is assigned to only one project at a time. Draw an ERD showing those entities
- 3- Given the following data attributes and entities, indicate which attributes could be identifiers for each of the entities. You may have to combine attributes or even add some attributes that are not listed. Map all of the attributes to their appropriate entity. Remember, each attribute should describe one and only one entity. Draw a rough draft entity relationship diagram.

Green Acres Real Estate System

Entities:

Seller	House	Closing
Buyer	Offer	Showing
Listing	Property	Room

Attributes:

Seller name	Square foot size	Seller address
House style	closing location	Listing price
Number of bathrooms	Garage size	Showing date
Garage location	Buyer name	Basement size
House heating method	Offer amount	Listing date
Property description	Offer date	Room type
Property size	Showing time	Room size
Elementary school zone	Buyer phone number	

Thank You Dr. Hatem June 2012



Answer all questions

Question one

- 1- Define the following terms:
 - a. Endogenous System
 - b. Exogenous System
 - c. Closed System
 - d. Open System
- 2- Differentiate between the following:
 - a. Continuous System and Discrete Systems
 - b. Stochastic model and Deterministic model
 - c. Static model and Dynamic model
- 3- A project has been defined to contain the following list of activities along with their completion time and dependencies:

1.	Requirements gathering	2	--
2.	Requirements prioritization	6	1
3.	Data analysis	3	2
4.	Logical design	7	2
5.	Physical design	6	2
6.	Interface design	1	3,4
7.	Report design	5	4,6
8.	Coding	4	6,7
9.	Testing and documenting	8	5,7
10.	Installation and training	2	8,9

- a. Draw a PERT diagram and Gant chart for the project;
- b. Calculate the earliest completion time for the project;
- c. Show the critical path.

Question Two

- 1- Define the following terms:
 - Model
 - System
 - Simulation
- 2- Draw the star schema for data warehouse development method?
- 3- For the following case study Draw Data flow diagram at all levels:
Joe the bookkeeper receives bounced checks from the bank. He fills out a Balance Correction Form and forwards it to the Correction Department so that the outstanding balance can be corrected. Joe sends a

Question (3) (20 Marks)

For the system that is shown in Fig. (2), when the start pushbutton is pressed, the motor (M) will move from left to right. When LS1 (2) is (ON), the motor stops, delay for 5 seconds then move to the home. When LS1 (1) is (ON), motor cuts off and the sequence is completed. Design a PLC programmed ladder diagram.

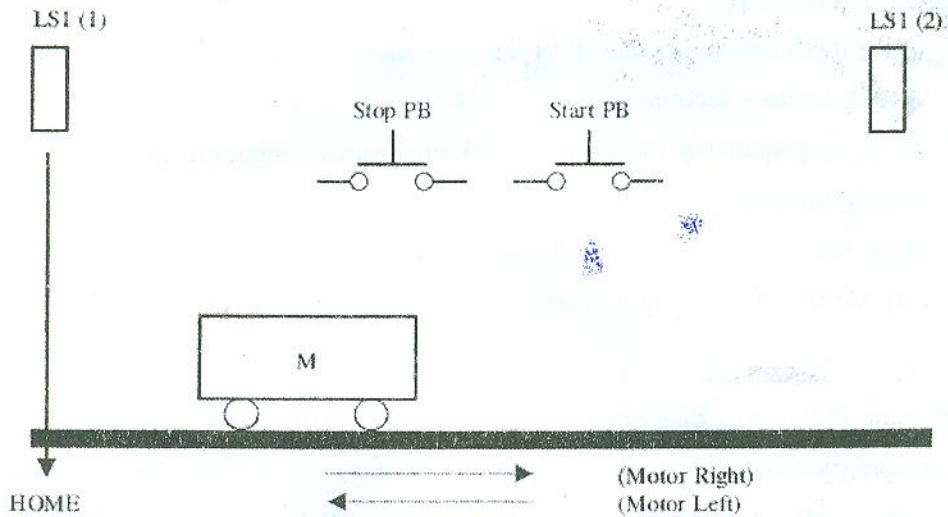

Fig. (2)

Question (5) (10 Marks)

Construct a PLC ladder program for a car parking system that is shown in Fig. (3). The program can control 100 cars at the maximum. Each time a car enters, PLC automatically adds it to a total sum of other cars found in the garage. Each car that comes out will automatically be taken off. When 100 cars park, a signal will turn on signaling that a garage is full and notifying other drivers not to enter because there is no space available.

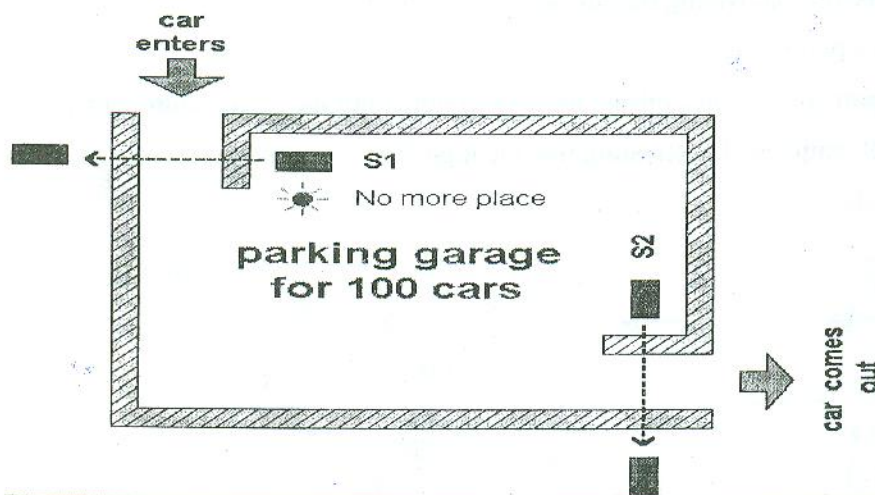

Fig. (3)

Good Luck

Course Title: Programmable Logic Controllers (PLCs) Course Code: CCE32**
Date: 10/6/2011 (Second term) Allowed time: 3 hrs

Year: 3rd
No. of Pages: (2)

Answer the following questions

Question (1) (15 Marks)

- Draw** a schematic diagram illustrating the memory map of PLC and **explain** the function of each memory section?
- Mention** graphically the types of rack enclosures containing I/O modules in PLCs and **explain** the differences between them?
- Draw** the block diagram and physical circuit of
 - AC/DC discrete input interface module
 - AC discrete output interface module

Question (2) (20 Marks)

Draw the PLC ladder diagram to implement a PLC system that controls a process consisting of two motors such that:

- Motor (**M1**) is running as long as limit switch (**LS1**) is not triggering.
- Motor (**M2**) starts with (**LS1**) action and continue running for 3 sec.
- After 3 sec. motor (**M1**) restarted and motor (**M2**) stopped
- The action is **cyclic**.

Question (3) (20 Marks)

Prepare the Ladder diagram for the process shown in Fig. (1). The sequence of operations is:

- The start button is momentarily closed, starting the pump.
- The tank fills, activating first the low-level, then the high-level sensor.
- Then the pump stops.
- The steam valve opens, raising the temperature until the temperature indicator is ON
- The tank empties, de-activating first the high-level, then the low-level sensor. Then the drain valve closes.

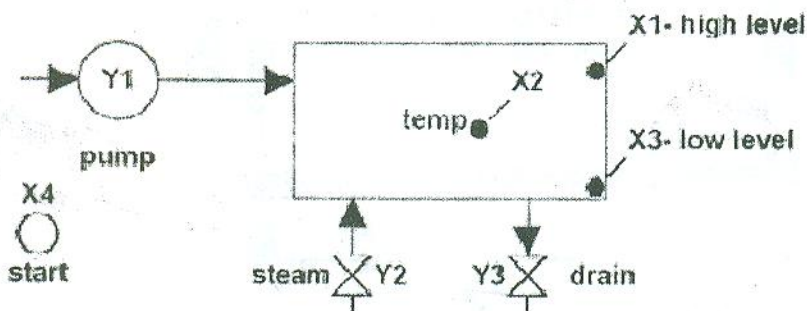

Fig. (1) Steam Cooker



Answer all questions

Question One

- 1- What are the differences between noise, data, information, knowledge and meta knowledge?
- 2- Define the term problem? What are the problem characteristics?
- 3- Explain the difference between the effective decision and efficient decisions?
- 4- What are the major components of DSS and briefly define each of them?
- 5- In the well known financial present value model consider the following case study:
The present value of payment of 100 000 EP, assume a 10 percent interest rate. Calculate the value after those five years.

Question Two

- 1- Define the term Manger? Are you a manger or not?
- 2- Maxwell Manufacturing makes two models of felt tip marking pens. Requirements for each lot of pens are given below.

	Flip top Model	Tiptop Model	Available
Plastic	3	4	36
Ink Assembly	5	4	40
Molding Time	5	2	30

The profit for either model is \$1000 per lot.

- a- What is the linear programming model for this problem?
- b- Find the optimal solution.
- 3- You are about to buy a Car. Follow Simon's phase model and describe the activities at each steps. Explain the support given to decision makers in each phase of decision process

Question Three

- 1- Draw the general structure of a Quantitative model, Define each term in the model
- 2- If you are a manger, How would you measure the productivity of
 - A salesperson
 - A professor
 - A student
- 3- What the searching approaches which can be used in the choice phase in DSS Simon model
- 4- Specify in a table the inputs, processes and outputs of the following systems
 - Post office
 - Elementary School
 - Social service agency

- 2- You are computing the SW cost and you need to determine the best way to compute it.
- 3- You are producing a generic SW and you need to choose the proper methods for collecting requirements.

(b) What is the origin of the following SW, and make a small note on each:

- 1- Printer driver 2- SQL server SW 3- Sony company Web page

(c) List how to be a good programmer and how to choose the suitable programming language for the application developed.

Problem number (4) (30 Marks)

a) Choose the correct answer for each of the following statements, then make a comment on your solution

(1) An iterative process of systems development in which requirements are converted to a working system that is continually revised through close work between an analyst and users is called:

- a. Joint Application Design b. Participatory Design
c. prototyping d. Systems Development Life Cycle

(2) Which of the following occurs during project execution?

- a. monitoring project progress against the baseline plan
b. conducting post-project reviews c. establishing the project initiation plan
d. establishing the project workbook

(3) When we are organizing the work in medium size companies with few members and many projects we use:

- a. SWAT team organization b. Hierarchical organization
c. Chief in programmers organization d. matrix organization

(b) Suggest at least three functions required in Videoplayer (مشغل فيديو) SW developed for a company. Draw the conceptual model and write the description of each function in a clear way. Also, add two non-functional requirements that could be required.

(c) Draw the PERT Chart for the following system tasks represented in the table:

Task number	Task name	Predecessor	Task time
1	Planning	-	1 week
2	Analysis	1	2 weeks
3	Interface design	2	2 weeks
4	Database design	2	3 weeks
5	Implementation	3, 4	4 weeks
6	Test	5	2 weeks
7	Documentation	5	2 weeks

Then through it find the following information:

- 1- Expected total time for system completion
- 2- Which tasks are performed in parallel (at the same time)
- 3- Which task is the first and which one is the last
- 4- If task 3 is delayed by 1 week, will this affect the total time of completion, make comments.
- 5- Draw the corresponding Gantt chart for this Pert chart.



Course Title: Software Engineering
Date: June 14th 2012 (Second term)

Course Code:
Allowed time: 3 hrs

Year: 3rd
No. of Pages: (2)

Remarks: Please Read the question more than once to fully understand it before you start solving, Do not forget to make verification and validation for your answers.

Problem number (1) (25 Marks)

- (a) You have been assigned project manager within an information systems organization. Your job is to build an application that is almost similar to other applications your team has built before, although this one is larger and more complex. Requirements have been documented by the customer. What software development cycle model would you choose and why. Describe in some details the role of each step and draw the model too.
- (b) If you are hired to work as a SW maintenance engineer at one of the leading companies (In Sha'a Allah), please answer the following questions and put them in an organized way to be easily read:
- 1- What are the task(s) you will have to do at your new job (i.e. your job description).
 - 2- What skills should you have to be a good worker at this job?
 - 3- What difficulties (الصعوبات التي ستواجهها) will you face during this job and how will you solve them?

Problem number (2) (20 Marks)

- (a) In a SW designed for a car rental shop (محل تأجير سيارات) there are many tasks required. They need to add, delete and update car's data, make car rental for a car which will include storing the customer data and the beginning date of the rental, and to search for a specific type of cars in the shop.
- 1- Determine the processes to be found in level-0 DFD.
 - 2- Determine the sources/sinks available.
 - 3- Determine the datastores required.
 - 4- Draw level-0 DFD.
 - 5- Draw context diagram and balance it with level-0.
 - 6- Make a suggestions for the database required for such system.
- (b) Compare between the following pairs:
- 1- Evolutionary and throw-away prototyping.
 - 2- Static and dynamic test techniques.
 - 3- Requirement verification and requirement validation
 - 4- Technical and operational feasibility

(c) What are the advantage and disadvantages of having custom software? What other sources of software if you can not make custom software for your job?

Problem number (3) (15 Marks)

- (a) For each of the following problems, find the best possible solution.

1- Some resources needed for the project is delayed (معرضة للتأخير) as they will be brought from outside the country.